



# CO-AE Carbon Monoxide Sensor High Concentration



**PATENTED**

**Figure 1 CO-AE Schematic Diagram**

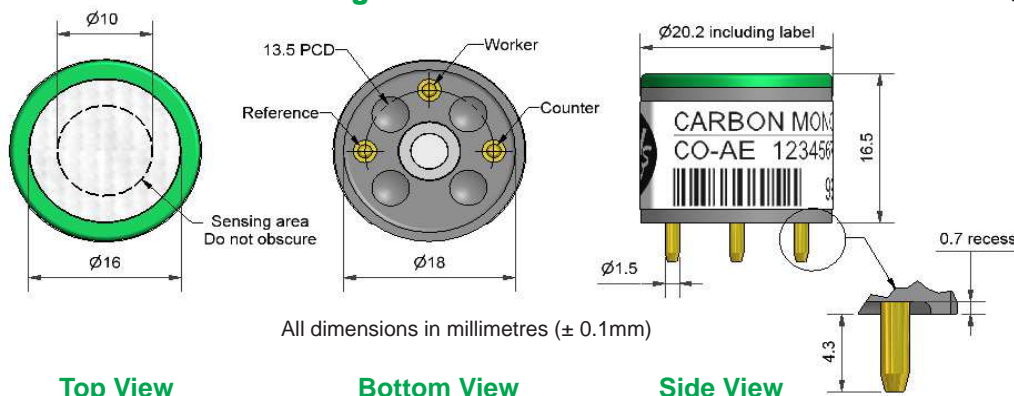

**Technical Specification**

PERFORMANCE	PERFORMANCE		
	Sensitivity	nA/ppm in 2,000ppm CO	
Response time	$t_{90}$ (s) from zero to 2,000ppm CO		< 50
Zero current	ppm equivalent in zero air		< $\pm 20$
Resolution	RMS noise (ppm equivalent)		< 5
Range	ppm CO limit of performance warranty		10,000
Linearity	ppm error at full scale, linear at zero and 2000ppm CO		< 0 to 500
Overgas limit	maximum ppm for stable response to gas pulse		100,000

LIFETIME	LIFETIME			
	Zero drift	ppm equivalent change/year in lab air		< 2
	Sensitivity drift	% change/year in lab air, monthly test		< 1
Operating life	months until 80% original signal (24 month warranted)		> 24	

ENVIRONMENTAL	ENVIRONMENTAL			
	Sensitivity @ -20°C	% (output @ -20°C/output @ 20°C) @ 400ppm CO		65 to 93
	Sensitivity @ 50°C	% (output @ 50°C/output @ 20°C) @ 400ppm CO		98 to 115
	Zero @ -20°C	ppm equivalent change from 20°C		< $\pm 2$
Zero @ 50°C	ppm equivalent change from 20°C		< $\pm 5$	

CROSS SENSITIVITY	CROSS SENSITIVITY			
	Filter capacity	ppm-hours	H <sub>2</sub> S	3,000,000
	Filter capacity	ppm-hours	NO <sub>2</sub>	8,000,000
	Filter capacity	ppm-hours	NO	200,000
	Filter capacity	ppm-hours	SO <sub>2</sub>	4,000,000
	H <sub>2</sub> S sensitivity	% measured gas @ 20ppm	H <sub>2</sub> S	< 0.1
	NO <sub>2</sub> sensitivity	% measured gas @ 10ppm	NO <sub>2</sub>	< 0.1
	Cl <sub>2</sub> sensitivity	% measured gas @ 10ppm	Cl <sub>2</sub>	< 0.2
	NO sensitivity	% measured gas @ 50ppm	NO	< 5
	SO <sub>2</sub> sensitivity	% measured gas @ 20ppm	SO <sub>2</sub>	< 0.1
	H <sub>2</sub> sensitivity	% measured gas @ 400ppm	H <sub>2</sub> at 20°C	< 75
	C <sub>2</sub> H <sub>4</sub> sensitivity	% measured gas @ 400ppm	C <sub>2</sub> H <sub>4</sub>	< 20
	NH <sub>3</sub> sensitivity	% measured gas @ 20ppm	NH <sub>3</sub>	< 0.1

KEY SPECIFICATIONS	KEY SPECIFICATIONS		
	Temperature range	°C	-30 to 50
	Pressure range	kPa	80 to 120
	Humidity range	% rh continuous	15 to 90
	Storage period	months @ 3 to 20°C (stored in sealed pot)	6
	Load resistor	$\Omega$ (recommended)	10 to 47
	Weight	g	< 6



At the end of the product's life, do not dispose of any electronic sensor, component or instrument in the domestic waste, but contact the instrument manufacturer, Alphasense or its distributor for disposal instructions.

**Apollosense Ltd**



# CO-AE Performance Data

Technical Specification

**Figure 2 Sensitivity Temperature Dependence**

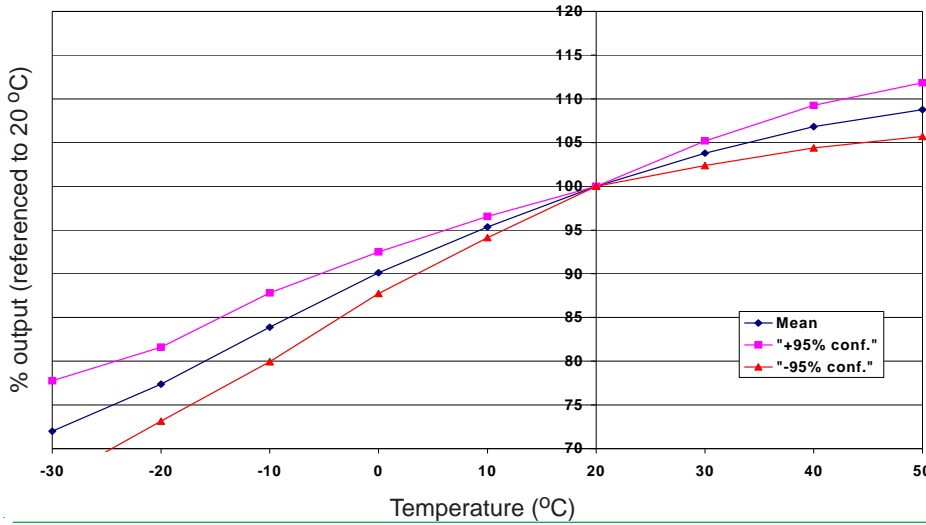

Figure 2 shows the variation in sensitivity caused by changes in temperature.

This data is taken from a typical batch of sensors. The mean and  $\pm$  95% confidence intervals are shown.

**Figure 3 Zero Temperature Dependence**

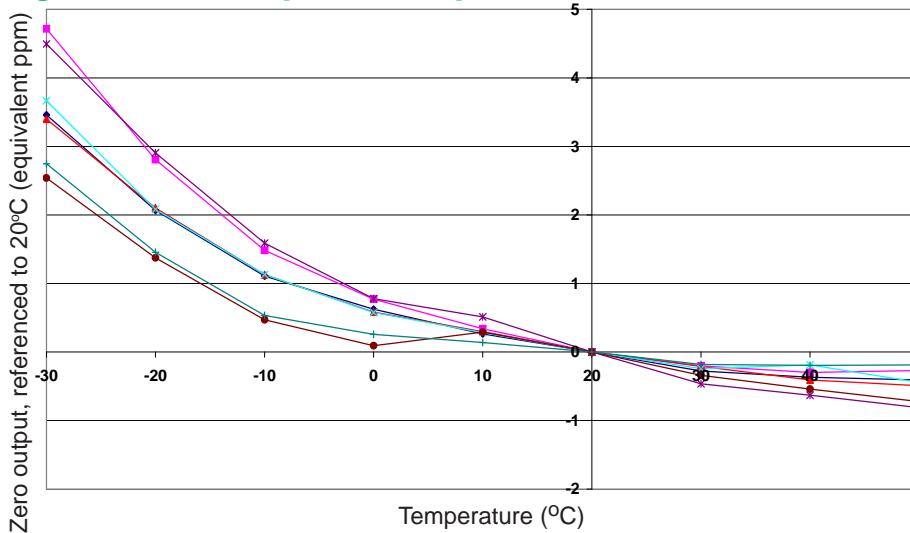
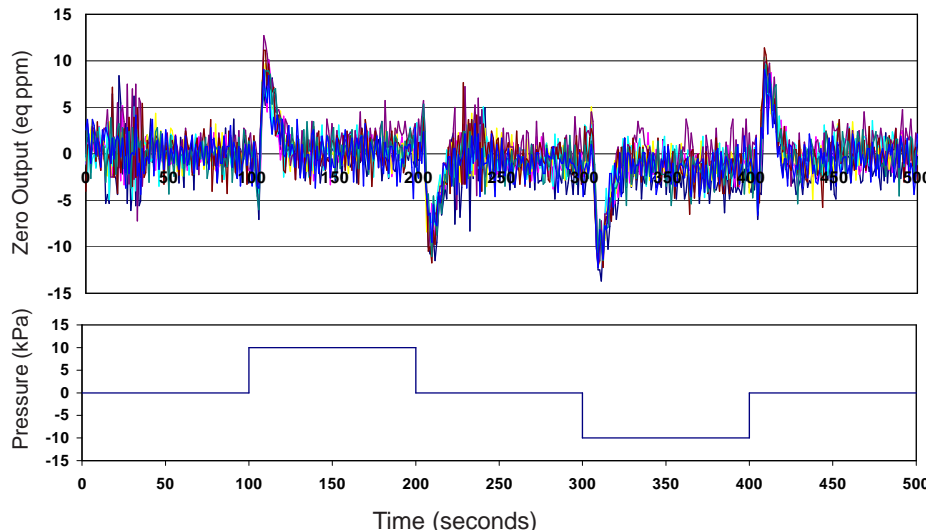

Figure 3 shows the variation in zero output caused by changes in temperature, expressed as ppm gas equivalent, referenced to zero at 20°C.

This data is taken from a typical batch of sensors.

**Figure 4 Zero Response to Pressure Steps**



From ambient pressure, sensors were subjected to both positive and negative 10kPa pressure steps. The small transient rapidly decays as the sensor returns to its zero baseline.